

Some Stability Results for Markovian Economic Semigroups^{*}

Leonard J. Mirman^a, Kevin Reffett^b and John Stachurski^{c,*}

^a*Department of Economics, University of Virginia, 114 Rouss Hall, Charlottesville
VA 22904-4182, USA*

`lm8h@cms.mail.virginia.edu`

^b*W. P. Carey School of Business, Arizona State University, Tempe AZ
85287-3806, USA*

`kevin.reffett@asu.edu`

^c*Department of Economics, The University of Melbourne, Melbourne VIC 3010,
Australia*

`j.stachurski@econ.unimelb.edu.au`

Abstract. The paper studies existence, uniqueness and stability of stationary equilibrium distributions in a class of stochastic dynamic models common to economic analysis. We provide applications to a heterogeneous agent model and two nonlinear multisector time series models with unbounded state space. *JEL classification:* C61; C62

Key words: Markov processes, asymptotic stability, semigroups

1 Introduction

Stability and instability of random dynamic systems are among the most fundamental themes of economic modeling. In the theory of long-run growth, stability is the key criterion behind convergence (or divergence) of cross-country

^{*} We are very grateful to the anonymous referee, whose insightful comments led to many improvements in the proofs. The third author thanks the Institute of Economic Research at Kyoto University and the Center for Operations Research and Econometrics at Université catholique de Louvain for hospitality over some of the period when these results were established.

^{*} Corresponding author: John Stachurski, Department of Economics, The University of Melbourne, Melbourne VIC 3010, Australia. Email: `j.stachurski@econ.unimelb.edu.au`. Phone: +61-3-8344-5289. Fax: +61-3-8344-6899.

income series. Stability analysis also has applications to business cycles, demand for credit and real cash balances, sustainable exploitation of renewable resources, and calculation of ruin probabilities from insurance premiums and claims. For models of economic learning stability determines the degree of convergence to long-run rational expectations equilibria. In econometrics many Monte Carlo calculations rely on the stability of Markov chains which have as their limit the distribution from which one wishes to sample.¹

In this paper we study the large class of dynamic economic models whose evolution can be described by a semigroup of operators $(\mathbf{P}_t)_{t \in \mathbb{T}}$ on $L_1 := L_1(S, \mathcal{B}, \lambda)$, where topological space S is the state space for the endogenous and exogenous variables of the economic system, \mathcal{B} is the Borel sets on S , and λ is some σ -finite measure. The interpretation is that if $\psi \in L_1$ is a density giving the probability distribution of the time zero state, then its image under \mathbf{P}_t is the density which gives the probability distribution of the state at time $t \in \mathbb{T}$. In other words, $t \mapsto \mathbf{P}_t\psi$ describes the orbit or *flow* of probability mass over time. Here \mathbb{T} may be either $[0, \infty)$ or $\mathbb{N}_0 := \mathbb{N} \cup \{0\}$.

Another possible interpretation in economics is that the initial condition ψ may describe the distribution at time zero of some variable across a heterogeneous agent population, such as initial wealth, or initial stock of physical or human capital. In this case, when \mathbf{P}_t is constructed to reflect the laws of motion that drive the system, $\mathbf{P}_t\psi$ will be the distribution of the same variable across agents at time t .

Our interest is in whether or not this system is (globally) asymptotically stable, in the sense that there is a unique density ψ^* with the property

$$\mathbf{P}_t\psi^* = \psi^*, \quad \forall t \in \mathbb{T}, \quad \text{and} \quad \lim_{t \rightarrow \infty} \|\mathbf{P}_t\psi - \psi^*\| = 0, \quad \forall \psi \in \mathcal{D}. \quad (1)$$

Here $\|\cdot\|$ is the L_1 norm, and $\mathcal{D} := \{\psi \in L_1 : \psi \geq 0 \text{ and } \|\psi\| = 1\}$ is the collection of all densities on S . The objective is to develop simple sufficient conditions for (1) that are both applicable and easy to verify for common economic and econometric models, as well as to extend existing results on asymptotic stability of Markov operator semigroups.

After stating our main stability result three applications are given. First we study the dynamics of a heterogeneous agent model recently introduced by Checchi and García-Peñalosa (2004), which is in turn a generalization of Galor and Zeira (1993). The second application is a short proof of asymptotic

¹ A *very* partial list of references is as follows. For stochastic growth see Mirman (1970) and Brock and Mirman (1972). For business cycles and stability see for example Long and Plosser (1983), or Farmer and Woodford (1997); for money demand see Lucas (1980), or Stokey Lucas and Prescott (1989). Sustainable exploitation is discussed in Mitra and Roy (2003). Bray (1982) and Evans and Honkapohja (2001) are well-known studies of stability in learning processes.

stability for the threshold autoregression model of Chan and Tong (1986) under suitable conditions on parameters and the shock. The third gives a general stability condition for models evolving on the positive cone of finite dimensional vector space. Such models are typical in economic applications.

Conditions for dynamic stability of stochastic economic models with a Markovian structure have been studied by many authors. Early references includes Mirman (1970) and Futia (1982). A very accessible survey is contained in Stokey, Lucas and Prescott (1989). For more recent work see, for example, Hopenhayn and Prescott (1992), Bhattacharya and Majumdar (2001, 2003), Stachurski (2002, 2003) or Nishimura and Stachurski (2004).

Many dynamic economies have a Markov structure. Recently, conditions for the existence of Markov transition rules have been found for economies with tax distortions, externalities, heterogenous agents, and so on. See, for example, Le Van, Morhaim and Dimaria (2002), or Mirman, Morand and Reffett (2004).

Mathematically, this work extends techniques developed by Lasota (1994), who introduced a new method to prove asymptotic stability of integral Markov semigroups. Lasota's elegant method exploits the continuity properties inherent in integral operator transforms, as well as the dual structure of the function space L_1 . As a result, no continuity conditions are required in the economic law of motion. For example, the heterogenous agents model for which we establish stability below has a discrete choice component, making the transition rule discontinuous.

Hopenhayn and Prescott (1992) also do not require continuity. On the other hand, they require monotonicity and this paper does not. However here the law of motion *must map densities into densities via an integral transform*. Typically this requires that the shocks that perturb the system are themselves distributed according to densities.

In Lasota's method the stability of integral semigroups is shown to be connected to L_1 weak precompactness of trajectories. The present paper suggests a new way to verify this property, by identifying a simple condition under which tight flows of densities generated by integral Markov semigroups are also uniformly integrable.²

In addition, we combine Meyn and Tweedie's (1993) very general notion of norm-like functions with Lasota's method to help identify tight trajectories. This proves to be useful when the state space is not itself a vector space, as so often happens in economic modeling (because prices and quantities are inherently nonnegative).

² Subsets of L_1 both tight and uniformly integrable are weakly precompact (Dunford and Pettis, 1940, Theorem 3.2.1).

2 Formulation of the Problem

First we give some definitions and examples. A linear operator \mathbf{P} sending $L_1(S, \mathcal{B}, \lambda)$ into itself (a self-mapping) is called a Markov operator if $\mathbf{P}\mathcal{D} \subset \mathcal{D}$. From the definition it follows that every Markov operator is both positive and a contraction.³ By a Markov semigroup is meant a collection $(\mathbf{P}_t)_{t \in \mathbb{T}}$ of self-mappings on L_1 such that

1. \mathbf{P}_t is a Markov operator for each $t \in \mathbb{T}$;
2. $\mathbf{P}_0 = I$, the identity map on L_1 ; and
3. $\mathbf{P}_s \circ \mathbf{P}_t = \mathbf{P}_{s+t}$ for all $s, t \in \mathbb{T}$ (semigroup under composition).

In practice Markov semigroups appear in several ways, probably the most common being via transition probability functions of Markovian motion on S . By a transition probability function we mean a map $p: \mathbb{T} \times S \times S \rightarrow [0, \infty)$ such that $(x, y) \mapsto p(t, x, y)$ is $\mathcal{B} \otimes \mathcal{B}$ -measurable, $\forall t \in \mathbb{T}$; and $p(t, x, \cdot) \in \mathcal{D}$ for each $t \in \mathbb{T}$ and $x \in S$. Heuristically, one thinks of $p(t, x, y)\lambda(dy)$ as the probability of traveling to y from x after t units of time have elapsed.

For example, financial time series are sometimes assumed to follow an Ornstein–Uhlenbeck process

$$dX_t = -\mu X_t dt + \sigma dB_t,$$

where μ, σ are positive constants and $(B_t)_{t=0}^\infty$ is a Brownian motion. In this case it is well-known that $(X_t)_{t=0}^\infty$ has transition probability function

$$p(t, x, y) = \frac{1}{\sqrt{2\pi v(t)}} \exp\left(-\frac{(y - xe^{-\mu t})^2}{2v(t)}\right),$$

where $v(t) := (\sigma^2/2\mu)(1 - e^{-2\mu t})$.

It is not difficult to verify that if p is a transition probability function then the collection of operators $(\mathbf{P}_t)_{t \in \mathbb{T}}$ defined by

$$(\mathbf{P}_t \psi)(y) := \int_S p(t, x, y) \psi(x) \lambda(dx) \text{ for } t > 0 \text{ and } \mathbf{P}_0 := I, \quad (2)$$

is a Markov semigroup. The density $\mathbf{P}_t \psi$ is then interpreted as the marginal distribution of the time t state given that p is the law of motion and ψ is the initial distribution of the state.

Markov semigroups with the representation (2) for some transition probability function p will be called *integral* Markov semigroups.

Discrete time Markovian systems may also generate integral Markov semigroups. Suppose that $p: S \times S \rightarrow [0, \infty)$ is jointly measurable and satisfies

³ That is, $\psi \geq 0$ implies $\mathbf{P}\psi \geq 0$, and $\|\mathbf{P}\psi\| \leq \|\psi\|$, $\forall \psi \in L_1$.

$p(x, \cdot) \in \mathcal{D}$ for all $x \in S$, where $p(x, y)\lambda(dy)$ is thought of as representing the probability that the state variable transits from x to y in one step. If we define

$$p(1, x, y) := p(x, y), \quad p(t+1, x, y) := \int_S p(t, x, u)p(u, y)\lambda(du), \quad (3)$$

then $p: \mathbb{T} \times S \times S \rightarrow [0, \infty)$ is a transition probability function for $\mathbb{T} = \mathbb{N}_0$, and $(\mathbf{P}_t)_{t \in \mathbb{T}}$ defined as in (2) is an integral Markov semigroup.

It is not difficult to check that in this case (i.e., when time is discrete) we have $\mathbf{P}_t = \mathbf{P}^t$, where \mathbf{P}^t is defined as the t -th iterate of the map $\mathbf{P}: L_1 \rightarrow L_1$,

$$(\mathbf{P}\psi)(y) := \int_S p(x, y)\psi(x)\lambda(dx). \quad (4)$$

As an application, consider the well-known threshold autoregression model (Chan and Tong, 1986). The model is a nonlinear AR(1) process with the form

$$X_{t+1} = \sum_{k=1}^K (A_k X_t + b_k) \mathbb{1}\{X_t \in B_k\} + \xi_t, \quad (5)$$

where X_t takes values in \mathbb{R}^N , the family of sets $(B_k)_{k=1}^K \subset \mathcal{B}$ is a partition of \mathbb{R}^N , and $(A_k)_{k=1}^K$ and $(b_k)_{k=1}^K$ are $N \times N$ -dimensional and $N \times 1$ -dimensional matrices respectively. As usual, $\mathbb{1}\{P\} = 1$ if the statement P is true and zero otherwise. The idea is that when X_t is in the region of the state space B_k , the state variable follows the law of motion $A_k X_t + b_k$. The shock ξ is assumed to be an independent and identically distributed \mathbb{R}^N -valued process with density g .

For this model $S = \mathbb{R}^N$, and λ is the Lebesgue measure. (In which case we write dx, dy instead of $\lambda(dx), \lambda(dy)$ etc., and \int for \int_S .) When the current state X_t is equal to the given constant $x \in \mathbb{R}^N$, a simple change of variable argument shows that the conditional density $p(x, \cdot)$ for the next period state X_{t+1} is

$$p(x, y) = g \left[y - \sum_{k=1}^K (A_k x + b_k) \mathbb{1}\{x \in B_k\} \right]. \quad (6)$$

Now the corresponding semigroup (\mathbf{P}_t) can be constructed from (2) and (3). As we noted above, defining \mathbf{P} as in (4) we get $\mathbf{P}_t = \mathbf{P}^t$, the t -th iterate of \mathbf{P} , for every $t \in \mathbb{T}$.

3 Results

In this section the main result is stated. To do so we first need some assumptions on the state space and the underlying measure.

Assumption 3.1 *The space S is σ -compact, in the sense that every open subset of S can be expressed as a countable union of compact sets; and the measure λ is locally finite.*⁴

The main application we envisage is that S is a Borel subset of finite dimensional vector space \mathbb{R}^N , and λ is the Lebesgue measure.

Now let $(\mathbf{P}_t)_{t \in \mathbb{T}}$ be a fixed integral Markov semigroup with transition probability function p . We consider some properties on this semigroup which are associated with stability. The first is a communication assumption:

Condition 3.1 *There exists an $s \in \mathbb{T}$ such that for all $\psi, \psi' \in \mathcal{D}$ we have $\lambda(\text{supp } \mathbf{P}_s \psi \cap \text{supp } \mathbf{P}_s \psi') > 0$.*

A Markov semigroup with this property is said to overlap supports.⁵

Condition 3.2 *For some $s \in \mathbb{T}$, there exists a continuous function $h: S \rightarrow \mathbb{R}$ such that $\sup_{x \in S} p(s, x, y) \leq h(y)$ for all $y \in S$.*

Condition 3.2 is a technical condition used here to translate tightness results into uniform integrability results for orbits of the Markov semigroup. To state our final condition we need the following definition.

Definition 3.1 *A nonnegative function $V: S \rightarrow \mathbb{R}$ is called norm-like if there exists a sequence of compact sets (K_j) in S with $K_j \uparrow S$ and $\inf_{x \in S \setminus K_j} V(x) \rightarrow \infty$ as $j \rightarrow \infty$.*⁶

Norm-like functions were introduced in relation to Markov chains by Meyn and Tweedie (1993). An example of such a function is the Euclidean norm in finite dimensional vector space, as can be easily verified by setting $K_j := j \cdot B$, where B is the unit ball.

Condition 3.3 *For some $s \in \mathbb{T}$, there exists a continuous norm-like function V and constants $\alpha, \beta \in [0, \infty)$, $\alpha < 1$, such that*

$$\int p(s, x, y) V(y) \lambda(dy) \leq \alpha V(x) + \beta, \quad \forall x \in S.$$

Conditions such as 3.3 are often called drift conditions. They ensures that the state variable tends to return to the “center” of the state space over time. Of course in an arbitrary topological space such as S there is no center as such, but we can generate the space using the expanding sequence of compact sets from the definition of the norm-like function V . This sequence provides a notion of expansion from the center of the space towards the edges.

⁴ Measure λ on (S, \mathcal{B}) is called locally finite if $\lambda(K) < \infty$ for all compact $K \subset S$.

⁵ Actually the usual definition of overlapping supports is weaker. Precisely, a Markov semigroup $(\mathbf{P}_t)_{t \in \mathbb{T}}$ overlaps supports iff $\forall \psi, \psi' \in \mathcal{D}, \exists s \in \mathbb{T}$ such that $\lambda(\text{supp } \mathbf{P}_s \psi \cap \text{supp } \mathbf{P}_s \psi') > 0$. For $f \in L_1$, $\text{supp } f := \{x : f(x) \neq 0\}$, which is defined up to a null set.

⁶ As usual, $K_j \uparrow S$ means that $K_j \subset K_{j+1}$, all j , and $\cup_{j=1}^{\infty} K_j = S$.

The main theorem can now be stated. The proof is given in Section 5.

Theorem 3.1 *Let $(\mathbf{P}_t)_{t \in \mathbb{T}}$ be an integral Markov semigroup. If Conditions 3.1–3.3 hold for common $s \in \mathbb{T}$, then $(\mathbf{P}_t)_{t \in \mathbb{T}}$ is asymptotically stable.*

4 Applications

In this section we give three applications of Theorem 3.1. All are in discrete time. The first studies long run dynamics of a heterogenous agent model introduced by Checchi and García-Peñalosa (2004). The model extends Galor and Zeira (1993) by introducing shocks to production. The shocks in their model take one of two possible values. We study a version with lognormally distributed shocks.

The second is a simple new proof of stability in L_1 norm of the threshold autoregression (TAR) model of Chan and Tong (1986) under suitable hypotheses on the coefficients. (Chan and Tong give an earlier proof using different techniques.) TAR models have recently found many applications in economics (c.f., e.g., Hansen 2001).

The third is a general condition for stability of systems evolving on the positive cone of finite dimensional Euclidean space. Many economic models have this property, given that prices and quantities are typically nonnegative.

4.1 Heterogenous Agents

Checchi and García-Peñalosa's (2004) extension of Galor and Zeira (1993) can be outlined as follows.⁷ Consumers live for two periods. In the first they decide whether or not to educate themselves. Study incurs a fixed cost f , but increases their individual labor input from 1 to $h > 1$ efficiency units. In the second they work for firms, which use the constant returns technology

$$Y_t = A_t K_t^\beta L_t^{1-\beta}, \quad (7)$$

where K_t is capital, $L_t = n_t + h s_t$ is labor, n_t and s_t are the amounts of unskilled and skilled labor respectively, and A_t is the current shock. The sequence $(A_t)_{t \geq 0}$ is independent. Let us assume it is lognormally distributed. That is, $\ln A_t \sim N(\mu, \sigma^2)$.

Dropping the time subscript for now, in the second period agent i receives utility

$$(1 - \alpha) \ln c_i + \alpha \ln b_i, \quad c_i + b_i \leq Y_i, \quad (8)$$

⁷ Refer to their paper for motivation and further details.

where c_i is consumption, b_i is a bequest to the next generation in his or her dynasty, and Y_i is individual income. Income Y_i is equal to either $Aw + Rx_i$ or $Awh + R(x_i - f)$ according to whether the agent is unskilled or skilled. Here Aw is the wage rate, R is the gross world interest rate and $x_{i,t} = b_{i,t-1}$ is the wealth of the agent. (In the term Aw , A is the shock and w is a constant depending on parameters and R , the value of which is determined by a profit maximization assumption.)

Optimal consumption implies that a fraction $(1 - \alpha)$ of Y_i is consumed and the remainder αY_i is bequest. From this result and (8) it can be deduced that agent i should go to school if and only if

$$v_u(x_i) := \mathbb{E} \ln(Aw + Rx_i) < \mathbb{E} \ln(Awh + R(x_i - f)) =: v_s(x_i). \quad (9)$$

Note that skill acquisition increases mean income whenever $h > 1 + (\mathbb{E}(A)w)^{-1}Rf$. On the other hand, the volatility of wage income for skilled workers is $\text{Var}(A)w^2h^2$, compared to $\text{Var}(A)w^2$ for unskilled workers.

Since $b_i = \alpha Y_i$, individual wealth evolves according to

$$x_{i,t+1} = \begin{cases} \alpha(A_t w + Rx_{it}) & \text{if } v_u(x_{it}) \geq v_s(x_{it}); \\ \alpha(A_t wh + R(x_{it} - f)) & \text{if } v_u(x_{it}) < v_s(x_{it}). \end{cases} \quad (10)$$

Following Checchi and García-Peñalosa we assume that $\alpha R < 1$.

Set $S = [0, \infty)$, and let λ be the Lebesgue measure. From (10) we can formulate the flow of wealth distributions over time as the orbit of an integral Markov semigroup (\mathbf{P}_t) by using the construction given in Section 2.

Recall that $p(x, \cdot)$ has the interpretation of the density representing the conditional distribution for the next period state, given that the current state is equal to $x \in S$. A simple change of variable argument applied to (10) shows that this distribution is

$$p(x, y) = g\left(\frac{y - \alpha Rx}{\alpha w}\right) \frac{1}{\alpha w} \cdot \mathbb{1}\{v_u(x) \geq v_s(x)\} + g\left(\frac{y - \alpha R(x - f)}{\alpha wh}\right) \frac{1}{\alpha wh} \cdot \mathbb{1}\{v_u(x) < v_s(x)\}, \quad (11)$$

where $g(x)$ is equal to the lognormal density when $x > 0$ and $g(x) = 0$ when $x \leq 0$. We have dropped the subscript i because all agents have the same law of motion.

A plot of p is given in Figure 1. The origin is the corner of the graph farthest from the viewer, and x and y increase in the direction of the arrows. The parameters are $w = 5$, $h = 7$, $R = 1.1$, $f = 6$, $\alpha = 0.15$, $\mu = 1$ and $\sigma = 0.5$.

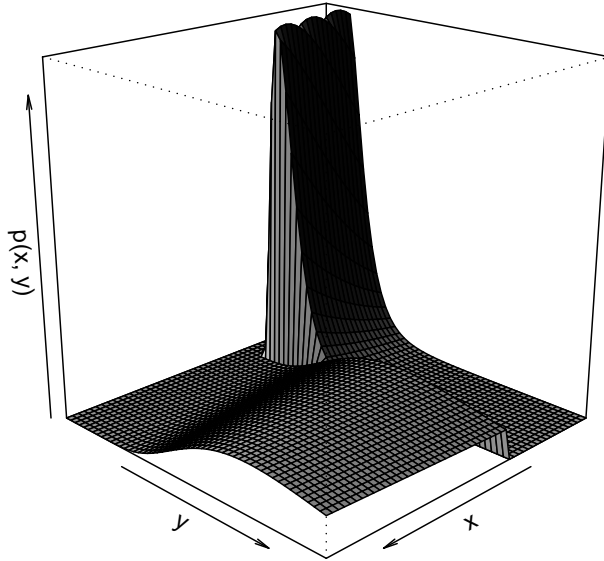

Fig. 1. The transition probability function (11)

Suppose now that $\psi_t \in \mathcal{D}$ is the current distribution of wealth across the agent population. In this case, the next period distribution ψ_{t+1} is given by

$$\psi_{t+1}(y) = \int p(x, y)\psi_t(x)dx. \quad (12)$$

Intuitively, (12) says that the probability of observing an agent with wealth y at $t + 1$ is equal to the probability that a dynasty's wealth moves from x to y in one period, times the probability of observing an agent with wealth x at t , summed across all x .

So if \mathbf{P} is defined by (4) for p given in (11), then (12) says that $\psi_{t+1} = \mathbf{P}\psi_t$. It follows that $\psi_t = \mathbf{P}^t\psi_0$, where ψ_0 is the initial wealth distribution, and \mathbf{P}^t is the t -th iterate of \mathbf{P} . In other words, the law of motion for the wealth distribution is $t \mapsto \mathbf{P}_t\psi_0$, where $\mathbf{P}_t := \mathbf{P}^t$.

Proposition 4.1 *For this economy the Markov semigroup (\mathbf{P}_t) is asymptotically stable. As a result, there is a unique long run distribution of wealth ψ^* , and, in addition, $\|\mathbf{P}_t\psi_0 - \psi^*\| \rightarrow 0$ as $t \rightarrow \infty$ for any initial distribution $\psi_0 \in \mathcal{D}$.*

An estimation of the long run distribution for wealth ψ^* is presented in Figure 2. The distribution is calculated using Glynn and Henderson's (2001)

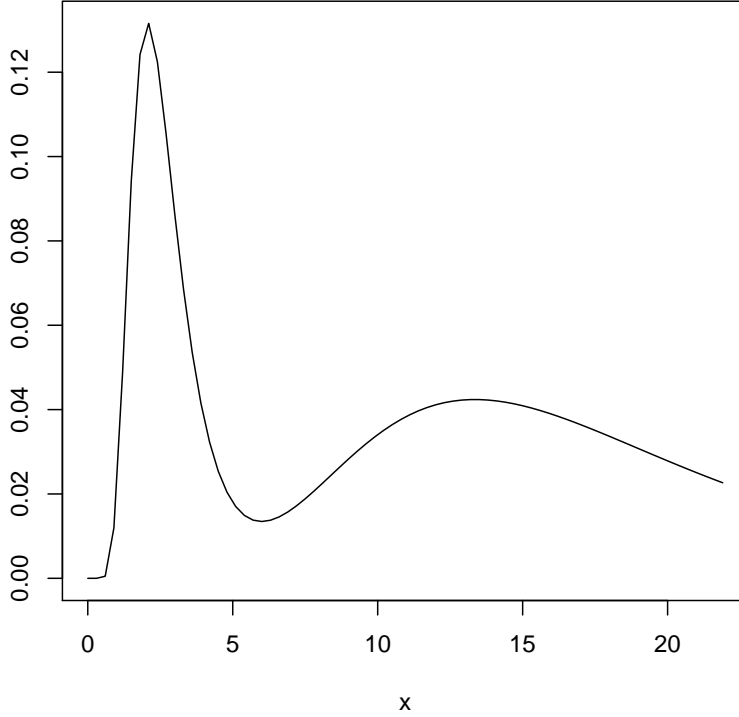

Fig. 2. The stationary distribution

“look-ahead” estimator

$$\psi^*(x) \simeq \frac{1}{T} \sum_{t=1}^T p(X_t, x), \quad (X_t)_{t=1}^T \text{ generated by (10)}. \quad (13)$$

The parameters are the same as for Figure 1.

Proof of Proposition 4.1. We check that the conditions of Theorem 3.1 hold for $s = 1$, recalling that $p(1, x, y) := p(x, y)$, where $p(x, y)$ is given by (11). First we show that Condition 3.1 holds, by way of the following claim:

$$\forall \psi \in \mathcal{D}, \exists N_\psi \in \mathbb{N} \text{ s.t. } \mathbf{P}\psi(y) > 0, \quad \forall y \geq N_\psi. \quad (14)$$

The claim is true, because $x \leq y$ implies $p(x, y) > 0$, and because there exists an N_ψ with $\int_0^{N_\psi} \psi(x) dx > 0$, so when $y \geq N_\psi$ we must have

$$\mathbf{P}\psi(y) \geq \int_0^{N_\psi} p(x, y)\psi(x) dx > 0.$$

That \mathbf{P} overlaps supports is now immediate from (14).

Regarding Condition 3.2, note that the lognormal density is bounded by a constant $M < \infty$, say. But then $p(x, y) \leq (\alpha w)^{-1}M$, which establishes the condition.

Regarding Condition 3.3, note that for our choice of S the identity $V(y) = y$ is a Lyapunov function. We have

$$\int yp(x, y)dy = \begin{cases} \alpha\mathbb{E}(A)w + \alpha Rx & \text{if } v_u(x) \geq v_s(x) \\ \alpha\mathbb{E}(A)wh + \alpha R(x - f) & \text{if } v_u(x) < v_s(x) \end{cases} \\ \leq \lambda x + \beta,$$

where $\lambda := \alpha R < 1$ and $\beta := \alpha\mathbb{E}(A)hw$. This establishes Condition 3.3, completing the proof of Proposition 4.1.

4.2 Threshold Autoregression

Recall the threshold autoregression model outlined in Section 2. An application of Theorem 3.1 to this model gives the following stability result.

Proposition 4.2 *Let $(\mathbf{P}_t)_{t \in \mathbb{T}}$ be the Markov semigroup generated by the dynamical system (5). Suppose that g is strictly positive on \mathbb{R}^N , that $g \leq M$ for some $M < \infty$, and that $\mathbb{E}\|\xi\| := \int \|z\|g(z)dz < \infty$. If, in addition, $\alpha := \max_k \alpha_k < 1$, where α_k is the spectral radius of A_k , then (\mathbf{P}_t) is asymptotically stable.*

For example, if ξ is multivariate normal then g satisfies all of the hypotheses of Proposition 4.2.

Proof. We check that the conditions of Theorem 3.1 hold for $s = 1$, recalling that $p(1, x, y) := p(x, y)$, where in this case $p(x, y)$ is given by (6). Condition 3.1 follows from positivity of g , which gives $p > 0$ everywhere via (6). Then (4) implies that $\text{supp } \mathbf{P}\psi > 0$ for every $\psi \in \mathcal{D}$. Condition 3.2 is immediate from the assumption $g \leq M$. Regarding Condition 3.3, let $V := \|\cdot\|$, the Euclidean norm on \mathbb{R}^N . Then for any $x \in \mathbb{R}^N$ we have

$$\begin{aligned} \int p(x, y)\|y\|dy &= \int \left\| \sum_{k=1}^K (A_k x + b_k) \mathbb{1}_{B_k}(x) + z \right\| g(z) dz \\ &\leq \sum_{k=1}^K \|A_k x + b_k\| \mathbb{1}_{B_k}(x) + \mathbb{E}\|\xi\| \\ &\leq \sum_{k=1}^K \alpha_k \|x\| \mathbb{1}_{B_k}(x) + \sum_{k=1}^K \|b_k\| + \mathbb{E}\|\xi\| \\ &\leq \alpha \|x\| + \beta, \quad \beta := \sum_{k=1}^K \|b_k\| + \mathbb{E}\|\xi\|. \end{aligned}$$

4.3 Models on the Positive Cone

In this section we consider models evolving on the positive cone $S = \times_{n=1}^N (0, \infty) \subset \mathbb{R}^N$, with λ the Lebesgue measure. We have deliberately excluded the boundaries, because we want to determine when the model will have a *nontrivial* limiting distribution, which is supported on the interior of the positive cone.

Consider the system $X_{t+1} = T(X_t, \xi_t)$, where the vector of shocks ξ_t takes values in S with density g , and $T: S \times S \rightarrow S$. The sequence (ξ_t) is independent. We assume that the map T is described by

$$T(x, z) = \begin{pmatrix} T_1(x) \cdot z_1 \\ \vdots \\ T_N(x) \cdot z_N \end{pmatrix}, \quad (15)$$

where each $T_n: S \rightarrow (0, \infty)$ is measurable. Note that in each sector we have required that the sectoral shock is multiplicative. Thus the model can be thought of as a multidimensional version of those studied by Horbacz (1989) and Stachurski (2003).

A standard change of variable argument now shows that when the current state is equal to x , the next period state has distribution

$$p(x, y) = g \left(\frac{y_1}{T_1(x)}, \dots, \frac{y_N}{T_N(x)} \right) \prod_{n=1}^N \frac{1}{T_n(x)}. \quad (16)$$

Consider the following conditions.

Condition 4.1 For each $r > 0$ let $A_r := \cup_{n=1}^N \{x \in S : x_n \leq r\}$. There is an $r > 0$ and a $k \in \mathbb{N}$ such that for all n between 1 and N , we have $T_n(x) \geq \min\{x_1, \dots, x_N\}$ on A_r and $T_n(x) \geq 1/k$ on $A_r^c := S \setminus A_r$.

The effect of Condition 4.1 is to push the state variable away from the boundaries of the state space and towards the center. This prevents the state in any given sector from becoming too small. The effect of the next condition is to prevent the state from becoming too large.

Condition 4.2 There exist constants $C, \gamma \in [0, \infty)$ such that $\gamma < 1$ and

$$\int \|T(x, z)\| g(z) dz \leq C + \gamma \|x\|, \quad \forall x \in S.$$

Condition 4.3 The joint distribution of $\xi = (\xi_1, \dots, \xi_N)$ satisfies

$$\int \sum_{n=1}^N \frac{1}{z_n} g(z) dz < 1.$$

Proposition 4.3, which is proved in Section 5, establishes the most difficult part of the following theorem.

Proposition 4.3 *Let $V: S \rightarrow \mathbb{R}$ be defined by $V(x) = \sum_{n=1}^N \frac{1}{x_n} + \|x\|$. If Conditions 4.1–4.3 hold, then there exist constants $\alpha, \beta \in [0, \infty)$ with $\alpha < 1$ and*

$$\int p(x, y)V(y)dy \leq \alpha V(x) + \beta, \quad \forall x \in S.$$

The main result of this section is

Theorem 4.1 *Let $(\mathbf{P}_t)_{t \in \mathbb{N}_0}$ be the Markov semigroup generated by the dynamical system (15). Let Conditions 4.1–4.3 be satisfied. If, in addition, $g > 0$ everywhere on S and there is a constant M such that $g(z) \prod_{n=1}^N z_n \leq M$ for all $z \in S$, then (\mathbf{P}_t) is asymptotically stable.*

For example, if ξ is multivariate lognormal then g satisfies all of the hypotheses of Theorem 4.1 under suitable restrictions on the mean and variance parameters.

Proof. We check that the conditions of Theorem 3.1 hold for $s = 1$. Condition 3.1 follows immediately from positivity of g and the expression (16). Condition 3.2 follows from the assumptions on g , because

$$p(x, y) = g\left(\frac{y_1}{T_1(x)}, \dots, \frac{y_N}{T_N(x)}\right) \prod_{n=1}^N \frac{y_n}{T_n(x)} \cdot \prod_{n=1}^N \frac{1}{y_n} \leq M \prod_{n=1}^N \frac{1}{y_n}.$$

Finally, Condition 3.3 follows from Proposition 4.3, as V is clearly norm-like.

5 Proofs

For the remainder of the paper, let us agree to call Markov operator \mathbf{P} asymptotically stable iff the semigroup $(\mathbf{P})_{t \in \mathbb{N}_0}$ defined by $\mathbf{P}_0 = I$, $\mathbf{P}_t = \mathbf{P}^t$ is asymptotically stable. The following result simplifies the proof of Theorem 3.1 by showing that in the case of Markov semigroups it is sufficient to verify stability for the discrete semigroup formed by iteration of some fixed member.

Lemma 5.1 *Let $(\mathbf{P}_t)_{t \in \mathbb{T}}$ be a Markov semigroup. If the operator \mathbf{P}_s is asymptotically stable for some $s \in \mathbb{T}$, then so is the semigroup $(\mathbf{P}_t)_{t \in \mathbb{T}}$.*

We provide a proof for completeness, although the ideas are available in the literature—see for example the discussion in Lasota and Mackey (1994, pp. 201–2 and Remark 7.4.2).

Proof. Write \mathbf{P} for \mathbf{P}_s . Let \mathbf{P} be asymptotically stable with fixed point $\psi^* \in \mathcal{D}$. Pick any $\varepsilon > 0$ and any $t \in \mathbb{T}$. Choose $N \in \mathbb{N}$ so that $\|\mathbf{P}^N(\mathbf{P}_t\psi^*) - \psi^*\| < \varepsilon$.

Then

$$\begin{aligned}\|\mathbf{P}_t\psi^* - \psi^*\| &= \|\mathbf{P}_t(\mathbf{P}^N\psi^*) - \psi^*\| = \|\mathbf{P}^N(\mathbf{P}_t\psi^*) - \psi^*\| < \varepsilon. \\ \therefore \|\mathbf{P}_t\psi^* - \psi^*\| &= 0.\end{aligned}$$

Regarding asymptotic stability, for $\psi \in \mathcal{D}$ choose $N \in \mathbb{N}$ so that $\|\mathbf{P}^N\psi - \psi^*\| < \varepsilon$. Then $t \geq N$ implies

$$\|\mathbf{P}_t\psi - \psi^*\| = \|\mathbf{P}_{t-N}(\mathbf{P}^N\psi) - \mathbf{P}_{t-N}\psi^*\| \leq \|\mathbf{P}^N\psi - \psi^*\| < \varepsilon,$$

where we have used the fact that every Markov operator is an L_1 contraction (Lasota and Mackey, Proposition 3.1.1).

We need the following auxiliary notion.

Definition 5.1 *Markov operator \mathbf{P} is called Lagrange stable on \mathcal{D} if the collection of points $\{\mathbf{P}^t\psi_0\} \subset \mathcal{D}$ is precompact for every $\psi_0 \in \mathcal{D}$.*⁸

The next result is due to Lasota (1994, Theorem 3.3).⁹

Theorem 5.1 *Markov operator \mathbf{P} on L_1 is asymptotically stable if and only if it is Lagrange stable on \mathcal{D} and overlaps supports.*

To establish Lagrange stability is in general difficult, as the criteria for norm-compact subsets of L_1 are quite restrictive. However, Lasota (1994, Theorem 4.1) has pointed out that in the case of *integral* Markov operators, Lagrange stability holds if and only if every trajectory $\{\mathbf{P}^t\psi\}$ is *weakly* precompact in L_1 .¹⁰

Theorem 5.2 *Let \mathbf{P} be an integral Markov operator on L_1 . The operator is Lagrange stable if and only if there exists a set $D_0 \subset \mathcal{D}$ such that D_0 is norm dense in \mathcal{D} and $\{\mathbf{P}^t\psi\}$ is weakly precompact for every $\psi \in D_0$.*

Weakly precompact sets in L_1 are relatively easy to identify. For example, order intervals are weakly compact. Also, there is the following characterization.

Definition 5.2 *Let M be a subset of \mathcal{D} . The collection of densities M is called tight if*

$$\forall \varepsilon > 0, \exists K \subset\subset S \text{ s.t. } \left\{ \int_{K^c} \psi(x)\lambda(dx) < \varepsilon, \quad \forall \psi \in M \right\}.$$

⁸ Precompact sets are those with compact closure. Here and below, unless otherwise stated, all topological concepts are with respect to the norm topology.

⁹ See also Stachurski (2002, 2003) for a proof of a slightly weaker result.

¹⁰ As usual, the adjective weakly refers to the topology induced on L_1 by its norm dual L_∞ .

The notation $K \subset\subset S$ means that K is a compact subset of S , and $K^c := S \setminus K$. The collection M is called uniformly integrable if

$$\forall \varepsilon > 0, \exists \delta > 0 \text{ s.t. } \lambda(A) < \delta \implies \left\{ \int_A \psi(x) \lambda(dx) < \varepsilon, \forall \psi \in M \right\}.$$

Theorem 5.3 (Dunford and Pettis, 1940, Theorem 3.2.1) *Let $M \subset \mathcal{D}$. If M is both tight and uniformly integrable then it is weakly precompact.*¹¹

Thus, in view of Theorem 5.2, to show Lagrange stability one need only find a norm-dense subset D_0 of \mathcal{D} such that all trajectories under \mathbf{P} with initial conditions in D_0 are both tight and uniformly integrable. Establishing uniform integrability, however, can itself be quite challenging. In this connection, we provide the following result.

Proposition 5.1 *Let $(\mathbf{P}_t)_{t \in \mathbb{T}}$ be an integral Markov semigroup on L_1 with transition probability function p . Fix $\psi \in \mathcal{D}$ and $s \in \mathbb{T}$. If the set of densities $\{\mathbf{P}_s^t \psi\}_{t \in \mathbb{N}_0}$ is tight, and, in addition, there exists a continuous function $h: S \rightarrow \mathbb{R}$ such that $p(s, x, y) \leq h(y)$ for all $x, y \in S$, then $\{\mathbf{P}_s^t \psi\}_{t \in \mathbb{N}_0}$ is also uniformly integrable.*

Proof. Fix $\varepsilon > 0$. Write \mathbf{P} for \mathbf{P}_s and $p(x, y)$ for $p(s, x, y)$. Since $\{\mathbf{P}^t \psi\}$ is tight, there exists a compact set K such that

$$\int_{K^c} \mathbf{P}^t \psi d\lambda < \frac{\varepsilon}{2}, \quad \forall t \in \mathbb{N}_0. \quad (17)$$

For arbitrary Borel set $A \subset S$, the decomposition

$$\int_A \mathbf{P}^t \psi d\lambda = \int_{A \cap K} \mathbf{P}^t \psi d\lambda + \int_{A \cap K^c} \mathbf{P}^t \psi d\lambda \quad (18)$$

holds. Consider the first term in the sum. We have

$$\begin{aligned} \int_{A \cap K} \mathbf{P}^t \psi(x) \lambda(dx) &= \int_{A \cap K} \left[\int p(x, y) \mathbf{P}^{t-1} \psi(x) \lambda(dx) \right] \lambda(dy) \\ &= \int \left[\int_{A \cap K} p(x, y) \lambda(dy) \right] \mathbf{P}^{t-1} \psi(x) \lambda(dx). \end{aligned}$$

But by the hypothesis and the fact that the image of a continuous real-valued function h on a compact set K is bounded by some constant $N < \infty$,

$$\int_{A \cap K} p(x, y) \lambda(dy) \leq \int_{A \cap K} h(y) \lambda(dy) \leq N \cdot \lambda(A).$$

Therefore,

$$\int_{A \cap K} \mathbf{P}^t \psi d\lambda = \int \left[\int_{A \cap K} p(x, y) \lambda(dy) \right] \mathbf{P}^{t-1} \psi d\lambda \leq N \lambda(A). \quad (19)$$

¹¹ We are using the fact that λ is locally finite.

Combining (17), (18) and (19), we obtain the bound

$$\int_A \mathbf{P}^t \psi(x) \lambda(dx) \leq N \cdot \lambda(A) + \frac{\varepsilon}{2}$$

for any t and any $A \in \mathcal{B}$. Setting $\delta := \varepsilon/(2N)$ now gives the desired result.

Regarding tightness, we need the following lemma (Meyn and Tweedie, 1993 Lemma D.5.3—the proof is straightforward).

Lemma 5.2 *A collection of densities $M \subset \mathcal{D}$ is tight whenever there exists a norm-like function V with $\sup_{\psi \in M} \int V \psi d\lambda < \infty$.*

In turn, Lemma 5.2 can be used to establish the next result.

Lemma 5.3 *Let $(\mathbf{P}_t)_{t \in \mathbb{T}}$, p , $s \in \mathbb{T}$, V , α and β be as in Theorem 3.1. If $\psi \in \mathcal{D}$ and $\int V \psi d\lambda < \infty$, then the trajectory $\{\mathbf{P}_s^t \psi\} \subset \mathcal{D}$ is tight.*

Proof. Let $\mathbf{P} := \mathbf{P}_s$. By Lemma 5.2, it suffices to show that

$$\sup_{t \in \mathbb{N}_0} \int V \mathbf{P}^t \psi d\lambda < \infty.$$

By the definition of \mathbf{P} ,

$$\begin{aligned} \int V(y) \mathbf{P}^t \psi(y) \lambda(dy) &= \int V(y) \int p(x, y) \mathbf{P}^{t-1} \psi(x) \lambda(dx) \lambda(dy) \\ &= \int \int V(y) p(x, y) \lambda(dy) \mathbf{P}^{t-1} \psi(x) \lambda(dx) \\ &\leq \int [\alpha V(x) + \beta] \mathbf{P}^{t-1} \psi(x) \lambda(dx) \\ &= \alpha \int V(x) \mathbf{P}^{t-1} \psi(x) \lambda(dx) + \beta \end{aligned}$$

By induction, then,

$$\int V(y) \mathbf{P}^t \psi(y) \lambda(dy) \leq \alpha^t \int V \psi d\lambda + \frac{\beta}{1 - \alpha},$$

which is sufficient for the proof, since $\alpha < 1$.¹²

We are now almost ready to complete the proof of Theorem 3.1. One last lemma is required:

Lemma 5.4 *Let D_0 be the set of all $\psi \in \mathcal{D}$ which vanish off a compact set. The set D_0 is norm-dense in \mathcal{D} .*

¹²These kinds of arguments are standard. See, for example, Lasota and Mackey (1994, §§10.5).

Proof. Pick any $\psi \in \mathcal{D}$. Since S is σ -compact, there exists a sequence of compact sets (K_n) with $K_n \uparrow S$. Let $\psi_n := \psi \mathbb{1}_{K_n} \in D_0$. We claim that $\lim_{n \rightarrow \infty} \|\psi_n - \psi\| = 0$. To see this, let $\nu(A) := \int_A \psi d\lambda$ for $A \in \mathcal{B}$. For $A_n := S \setminus K_n$ clearly $A_n \downarrow \emptyset$. As $\nu(A_1) \leq \nu(S) = 1$, it follows that $\lim_{n \rightarrow \infty} \nu(A_n) = 0$. On the other hand,

$$\begin{aligned} \nu(A_n) &= \int_{S \setminus K_n} \psi d\lambda = \int_S |\psi - \psi_n| d\lambda = \|\psi_n - \psi\|. \\ \therefore \quad \lim_{n \rightarrow \infty} \|\psi_n - \psi\| &= 0. \end{aligned}$$

Proof of Theorem 3.1. Let $s \in \mathbb{T}$ be as in the statement of the theorem. By Lemma 5.1 it suffices to prove asymptotic stability of \mathbf{P}_s when Conditions 3.1–3.3 hold. By Theorem 5.1 we need to show that \mathbf{P}_s is Lagrange stable and overlaps supports. From Condition 3.1 \mathbf{P}_s overlaps supports. Regarding Lagrange stability, Theorem 5.2, Theorem 5.3 and Lemma 5.4 together imply that \mathbf{P}_s will be Lagrange stable if $\{\mathbf{P}_s^t \psi\}$ is tight and uniformly integrable for every $\psi \in D_0$, the densities which vanish off a compact set.

So pick any $\psi \in D_0$. By Proposition 5.1 and Condition 3.2, it is sufficient to show that $\{\mathbf{P}_s^t \psi\}$ is tight. By Condition 3.3 and Lemma 5.3, $\{\mathbf{P}_s^t \psi\}$ will be tight whenever $\int V \psi d\lambda < \infty$. But this must be true, because ψ has compact support, and the norm-like function V is continuous. The proof is now complete.

It just remains to establish Proposition 4.3.

Proof of Proposition 4.3. By using a change of variable with the expression (16) we get

$$\begin{aligned} \int p(x, y) V(y) dy &= \int V(T(x, z)) g(z) dz \\ &= \int \sum_{n=1}^N \frac{1}{T_n(x) z_n} g(z) dz + \int \|T(x, z)\| g(z) dz. \end{aligned}$$

For $x \in A_r$,

$$\begin{aligned} \int \sum_{n=1}^N \frac{1}{T_n(x) z_n} g(z) dz &\leq \int \sum_{n=1}^N \frac{1}{z_n} g(z) dz \frac{1}{x_1 \wedge \cdots \wedge x_N} \\ &\leq \int \sum_{n=1}^N \frac{1}{z_n} g(z) dz \sum_{n=1}^N \frac{1}{x_n}. \end{aligned}$$

Setting $\theta := \int \sum_{n=1}^N \frac{1}{z_n} g(z) dz < 1$, then,

$$\int \sum_{n=1}^N \frac{1}{T_n(x) z_n} g(z) dz \leq \theta \sum_{n=1}^N \frac{1}{x_n} + k, \quad \forall x \in S, \quad (20)$$

where we have used the previous bound on A_r with the bound

$$\int \sum_{n=1}^N \frac{1}{T_n(x)z_n} g(z) dz \leq k \text{ on } A_r^c.$$

Combining (20) with Condition 4.2, then,

$$\int p(x, y)V(y)dy \leq \theta \sum_{n=1}^N \frac{1}{x_n} + k + C + \gamma\|x\|$$

for all $x \in S$. Setting $\alpha := \theta \vee \gamma < 1$ and $\beta := k + C$ gives the desired result.

References

- [1] Bhattacharya, R. and M. Majumdar (2001), “On a class of stable random dynamical systems: theory and applications,” *Journal of Economic Theory* 96, 208–229.
- [2] Bhattacharya, R. and M. Majumdar (2003), “Dynamical systems subject to random shocks: An introduction,” *Economic Theory* 23 (1), 1–12.
- [3] Bray, M. (1982), “Learning, estimation and the stability of rational expectations,” *Journal of Economic Theory* 26, 318–339.
- [4] Brock, W. A. and L. Mirman (1972), “Optimal economic growth and uncertainty: the discounted case,” *Journal of Economic Theory* 4, 479–513.
- [5] Chan, K. S. and Tong, H. (1986), “On estimating thresholds in autoregressive models,” *Journal of Time Series Analysis* 7, 179–90.
- [6] Checchi, D. and C. García-Peñalosa (2004), “Risk and the distribution of human capital,” *Economics Letters* 82 (1), 53–61.
- [7] Dunford, N. and B. J. Pettis (1940), “Linear operations on summable functions,” *Transactions of the American Mathematical Society* 47, 323–392.
- [8] Evans, G. W., and S. Honkapohja, (2001), *Learning and expectations in macroeconomics*, Princeton: University Press.
- [9] Farmer, R. and M. Woodford (1997), “Self-fulfilling prophecies and the business cycle,” *Macroeconomic Dynamics* 1 (4), 740–769.
- [10] Futia, C. A. (1982), “Invariant distributions and the limiting behavior of Markovian economic models,” *Econometrica* 50, 377–408.
- [11] Galor, O. and J. Zeira (1993), “Income distribution and macroeconomics,” *Review of Economic Studies* 60 (1) 35–52.
- [12] Glynn, P. W. and S. G. Henderson (2001), “Computing densities for Markov chains via simulation,” *Mathematics of Operations Research* 26, 375–400.

- [13] Hansen, B. (2001), “Threshold autoregression with unit root,” *Econometrica* 69 (6), 1555–96.
- [14] Hopenhayn, H. A. and E. C. Prescott (1992), “Stochastic monotonicity and stationary distributions for dynamic economies,” *Econometrica* 60, 1387–1406.
- [15] Horbacz, K. (1989), “Asymptotic stability of dynamical systems with multiplicative perturbations,” *Annales Polonici Mathematici* 50, 209–218.
- [16] Lasota, A. (1994), “Invariant principle for discrete time dynamical systems,” *Universitatis Iagellonicae Acta Mathematica* 31, 111–127.
- [17] Lasota, A. and M. C. Mackey (1994), *Chaos, fractals and noise: stochastic aspects of dynamics*, 2nd edition, New York: Springer-Verlag.
- [18] Le Van, C. L. Morhaim and C.H. Dimaria (2002), “The discrete time version of the Romer model,” *Economic Theory* 20 (1), 133–158.
- [19] Long, and Plosser (1983), “Real business cycles,” *The Journal of Political Economy* 91 (1), 39–69.
- [20] Lucas, R. (1980), “Equilibrium in a pure currency economy,” *Economic Inquiry* 18, 203–220.
- [21] Meyn, S. P. and Tweedie, R. L. (1993), *Markov chains and stochastic stability*, London: Springer-Verlag.
- [22] Mirman, L. J. (1970), *Two essays on uncertainty and economics*, Ph.D. Thesis, University of Rochester.
- [23] Mirman, L.J., O.F. Morand and K. Reffett (2004), “A qualitative approach to Markovian equilibrium in infinite horizon economies with capital,” (manuscript).
- [24] Mitra, T. and S. Roy (2003), “Optimal exploitation of renewable resources under uncertainty and the extinction of species,” CAE Working Paper 03-10, Cornell.
- [25] Nishimura, K. and J. Stachurski (2004), “Stability of stochastic optimal growth models: a new approach,” *Journal of Economic Theory* in press.
- [26] Stachurski, J. (2002), “Stochastic optimal growth with unbounded shock,” *Journal of Economic Theory* 106, 40–65.
- [27] Stachurski, J. (2003), “Economic dynamical systems with multiplicative noise,” *Journal of Mathematical Economics* 39 (1–2), 135–152.
- [28] Stokey, N. L., R. E. Lucas and E. C. Prescott (1989), *Recursive Methods in Economic Dynamics*, Harvard: University Press.